



PRODUCT SPECIFICATION

3D Led Pixel Ball

SH-O20A02





Product Feature

- ◇ Independent intellectual property rights, patented design, dedicated to engineering projects.
- ◇ These products are made by SMD 3535RGB high brightness LED with big view angle.
- ◇ It adopts PU glue filling glue, which is not easy to crack and has high product protection grade.
- ◇ The wire and outer casing are made of cold resistant, UV resistant and flame retardant materials, suitable for long-term outdoor use.

Size Chart

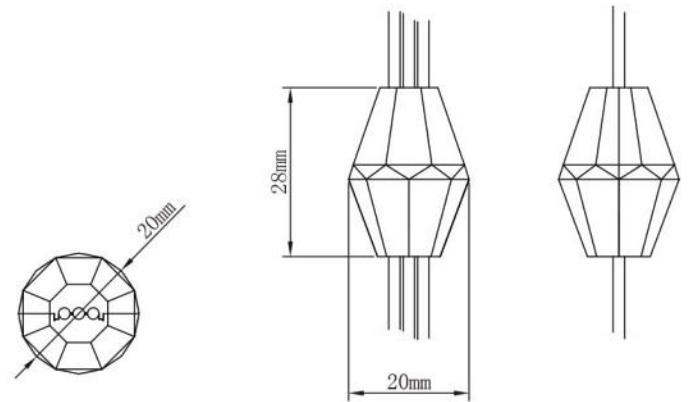

Specification

Model:	O20A02
Voltage:	DC12V
Power:	0.7W
LED Type & Qty:	SMD 3535 RGB 2pcs
Chip Type:	UCS1903B
Control mode:	SPI
Shell Material:	PC
Gray Level:	8 Bit 256 grade
IP Grade:	IP32 / IP65
Brightness:	≥4800MCD
wavelength:	R : 615-630nm G : 525-545nm B : 460-480nm
Chip Brand:	Sanan
Lifespan:	≥30000H
Beam Angle:	≥120°
Work Temp:	-20°C~+60°C
Store Temp:	-40°C~+75°C

Light Distribution Curve

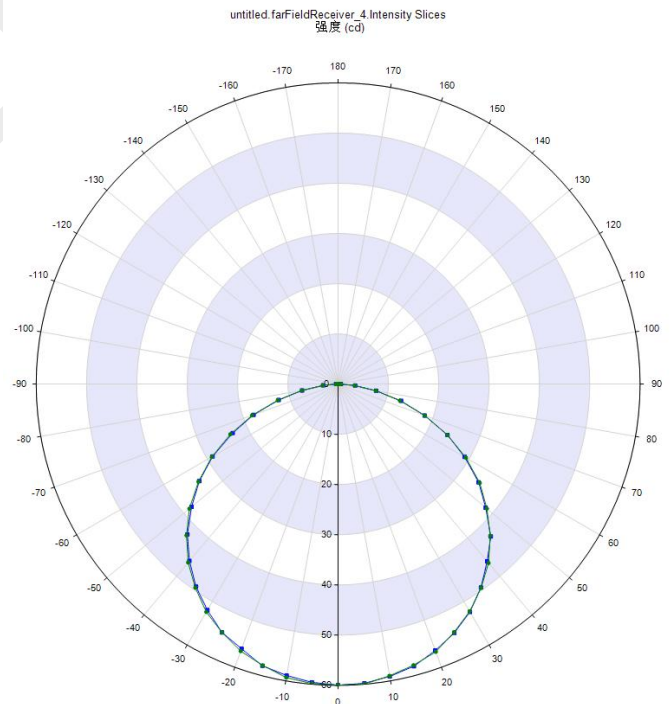



Application

- ◆ Building lighting decoration
- ◆ Media facade lighting
- ◆ Large shopping mall exterior
- ◆ Entertainment or stage lighting, such as clubs and KTV
- ◆ Hotels led screen

Reliability Test Item And Conditions

Test Item	Test Conditions	Test Duration	Judgement standard
Power Test	Input Voltage 12V, Ta=25°C±5°C	30min	Wattage 0.65w-0.75w
Temperature Test	Input Voltage:12.5V with white color	30min	≤60°C
Drop Test	Free fall at 1.2m height	10 Cycles	No damage to the appearance, normal function
Thermal Shock	-40°C(30min) ~ 100°C (30min)	200 Cycles	No damage to the appearance, normal function
Salt Spray Test	5% NaCl	72H	The material is non-corrosive and functional
Anti-UV Test	UV-A, 350-400nm, 60°C	72H	The material is free from aging and discoloration, functioning normally
Switching Cycle Test	ON 25 second / OFF 5 second, ON/OFF cycle	48H / 5000 cycle	Functioning normally
Voltage Test	DC 500V	Once	Functioning normally
ESD Test	3000V	Once	Functioning normally
High and Low Temperature Test	-30°C~65°C, RH 85%	72H	Functioning normally
Tensile Test	Input/output line, pull force 20KG or more	Once	The wire is not broken and functions normally
Vibration Test	Horizontal and vertical direction	4H	Functioning normally
IP Rating	IP68 0.5m underwater	48H	Functioning normally
Flame Retardant Rating	UL94-V0	10 Cycle	Self-extinguishing from the fire, no burning matter falling



Connection Diagram

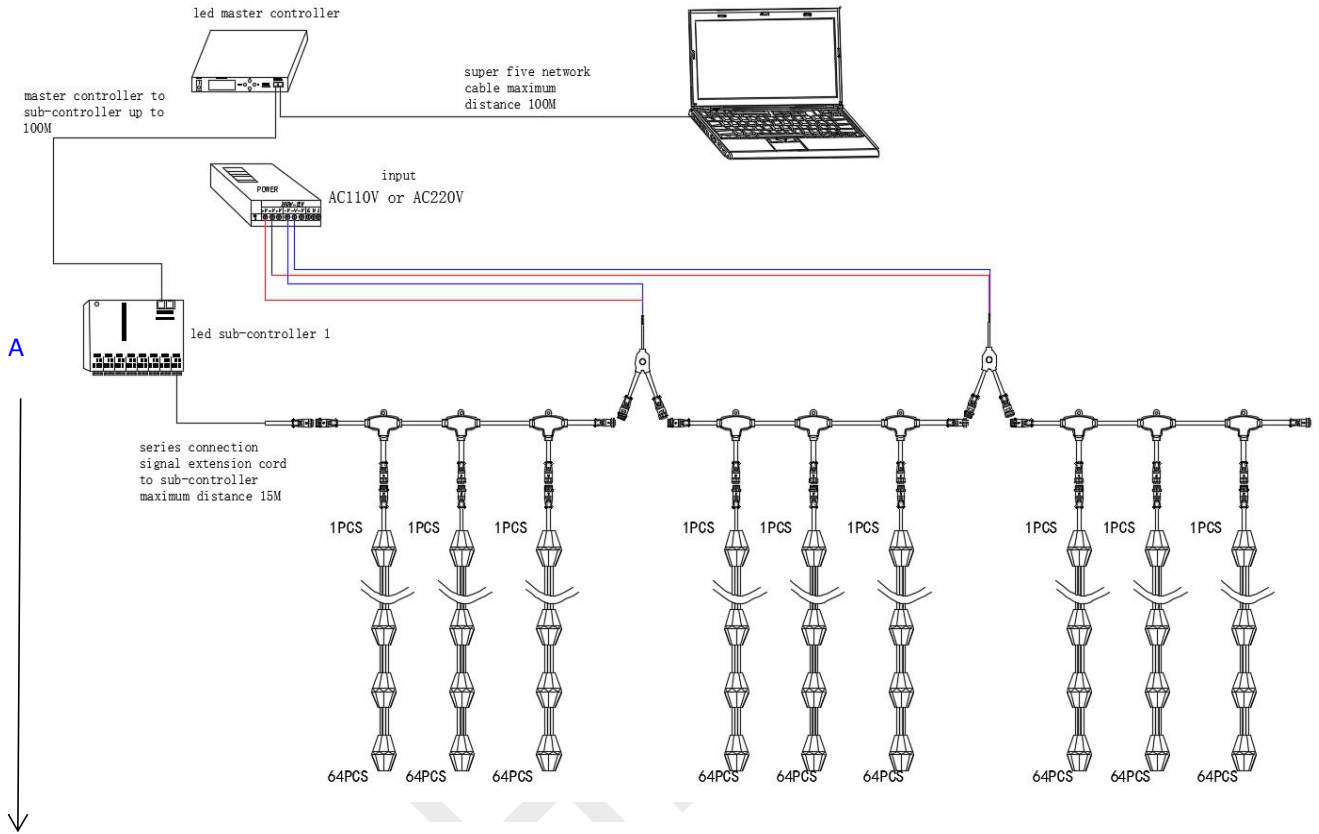

Magnified view A

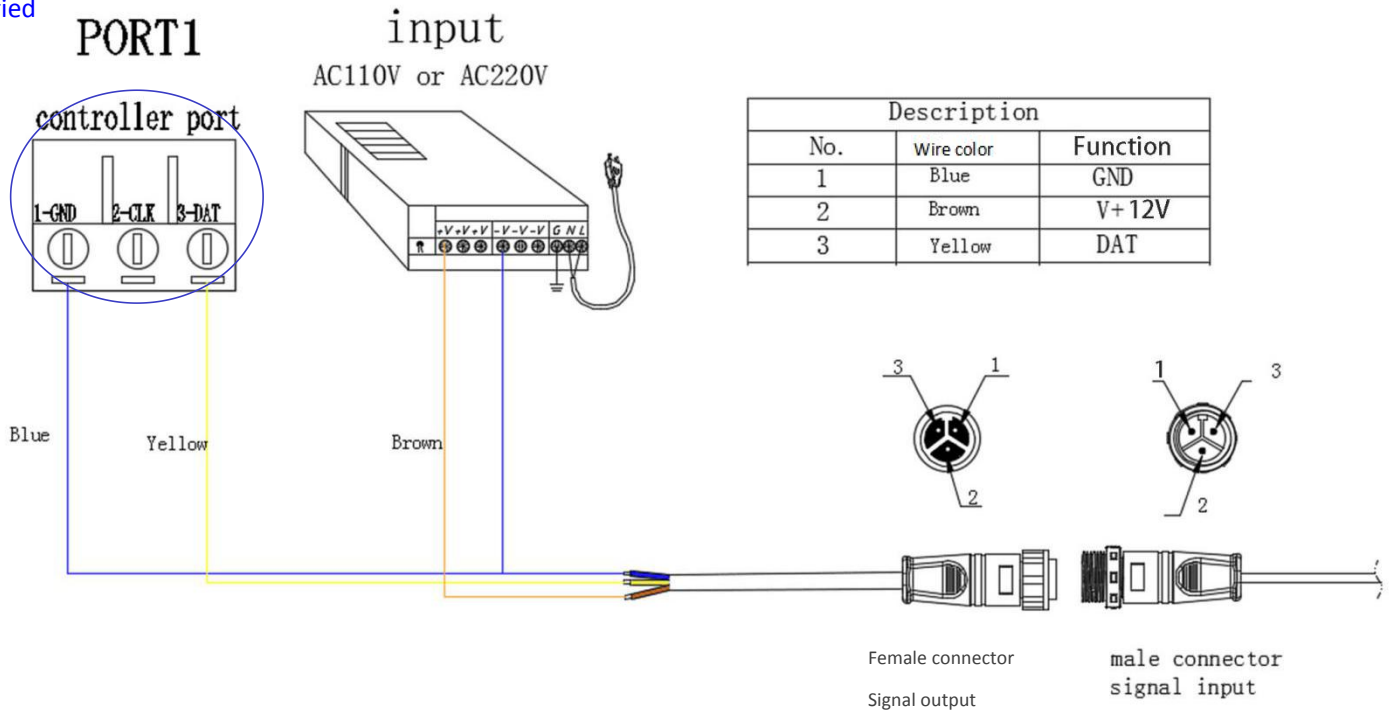



Installation Diagram

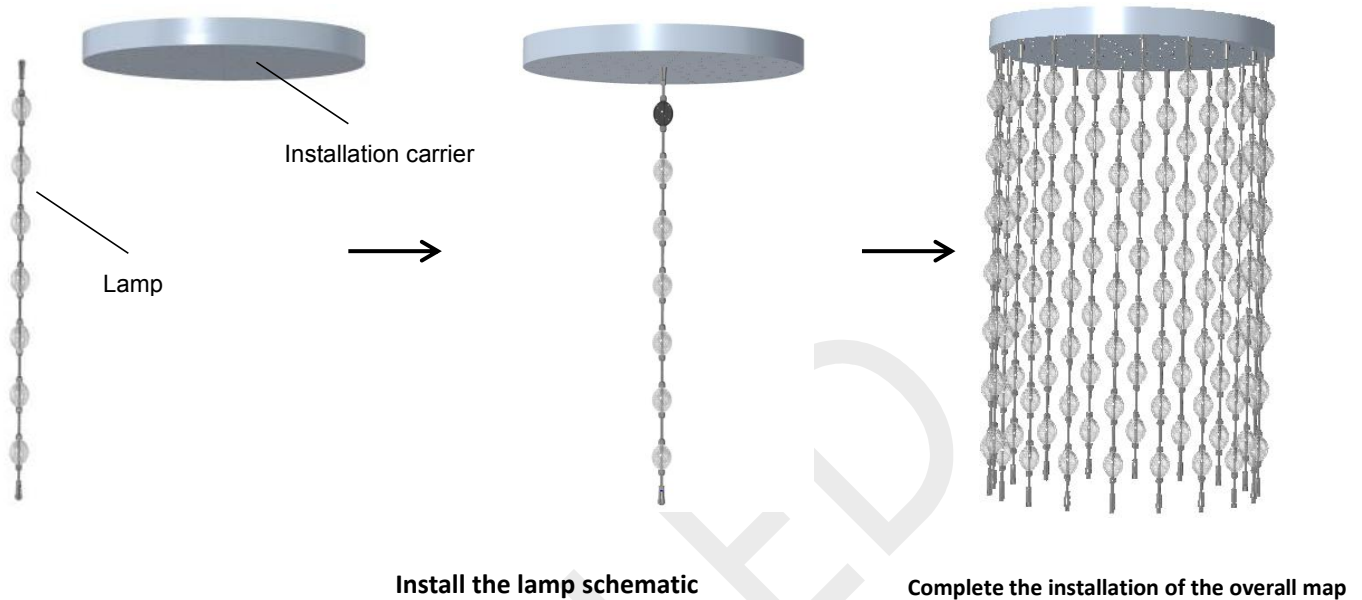

Notes

1. The output voltage of the power supply cannot be higher than the rated voltage, otherwise it will cause damage to the luminaire.
2. Do not carry live work.
3. All power cords and wire connections should be waterproofed after soldering.
4. . Non-professionals, please do not replace the controller and power supply at will, avoid wiring errors and cause malfunctions.



Project Case

